

**Citroën C4 Cactus 07/2014 >> 02/2018**  
**Citroën C4 Cactus 03/2018 >>**

**Partnr.: PE-065-B1U**

- Fitting instructions electric wiring kit tow bar with 12-N socket up to DIN/ISO Norm 1724.
- We would expressly point out that assembly not carried out properly by a competent installer will result in cancellation of any right to damage compensation, in particular those arising by virtue of the product liability act.
- Contents of these kits and their fitting manuals are subject to alteration without notice, please ensure that these instructions are read and fully understood before commencing installation.
- Do not overload circuits; the maximum loads per connection are detailed in this manual.
- Attention! Before Installation, please read this manual carefully and inform your customer to consult the vehicle owners manual to check for any vehicle modifications required before towing.
- In the event of functional problems, troubleshooting must be limited to about 0.5 hours, contact the technical support:  
[ukts@ecs-electronics.com](mailto:ukts@ecs-electronics.com) / 07440 202 052.



# Part list

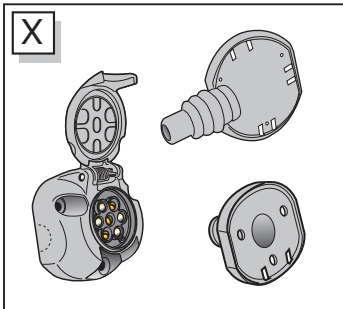
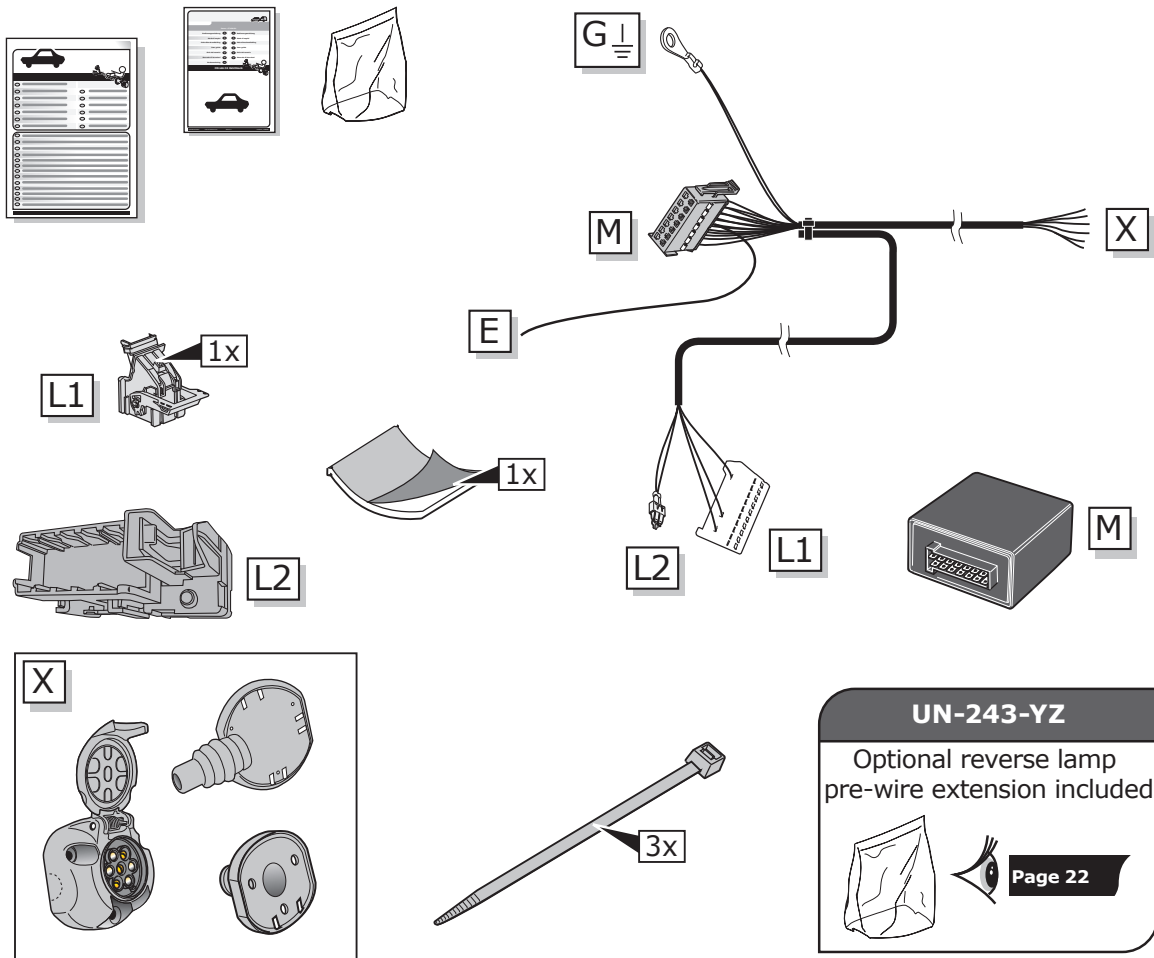
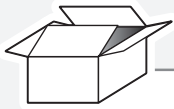

**UN-243-YZ**  
 Optional reverse lamp  
 pre-wire extension included

**Page 22**

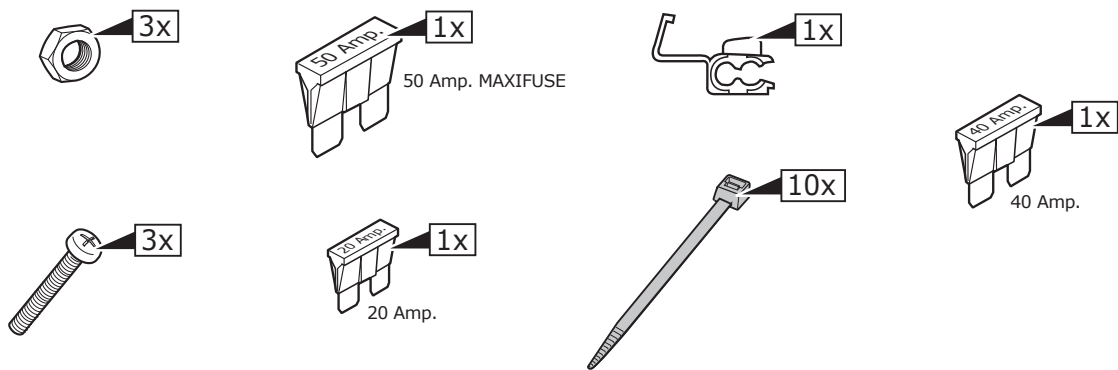

**INFO**

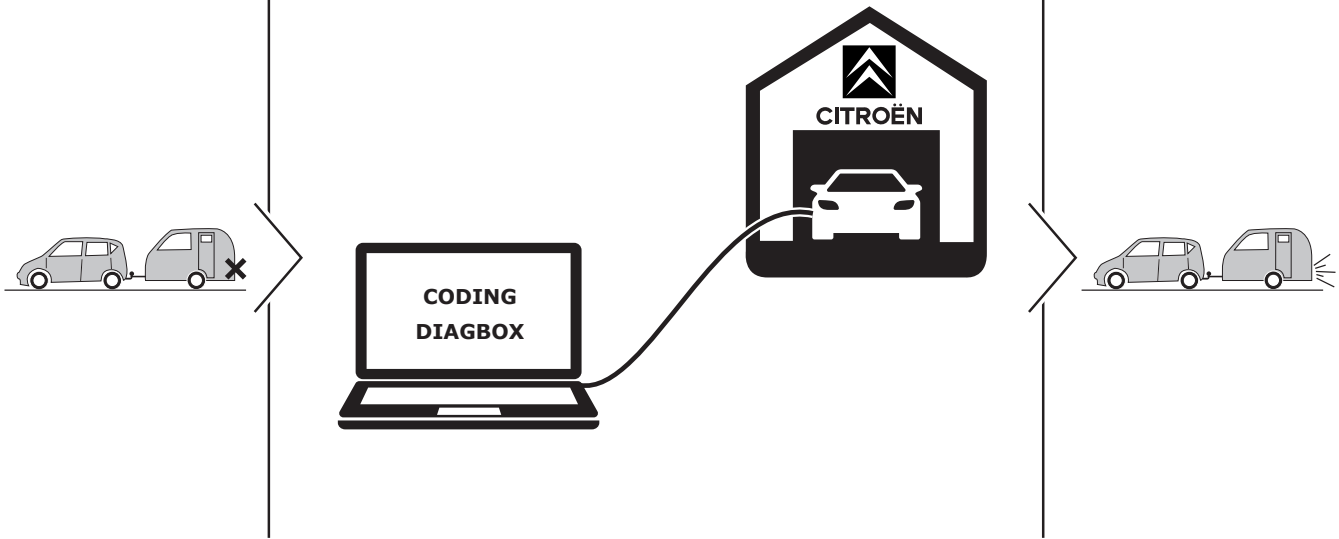

**Coding required for trailer lighting functions**

**ROUTING**

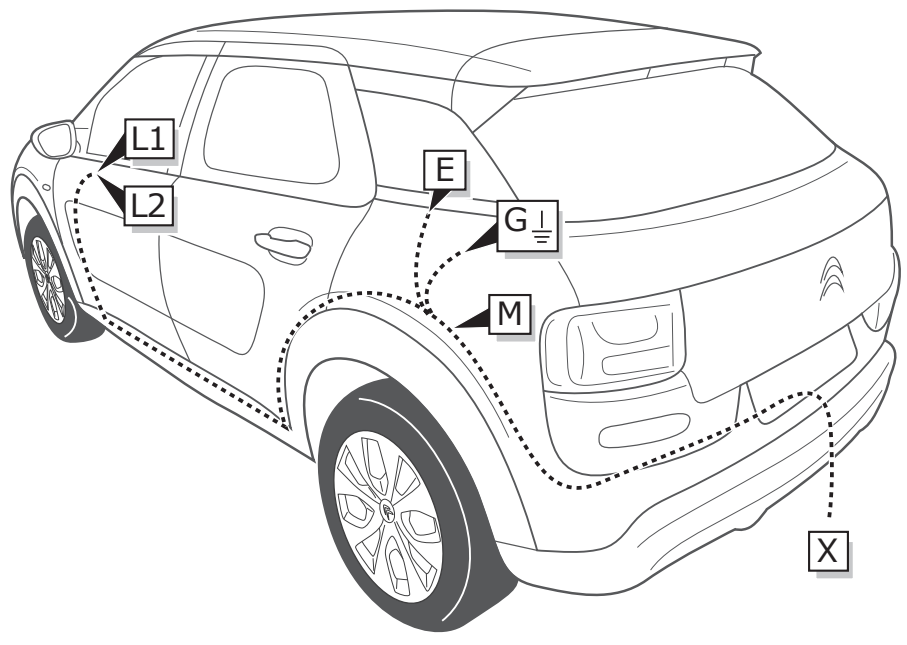

**1**

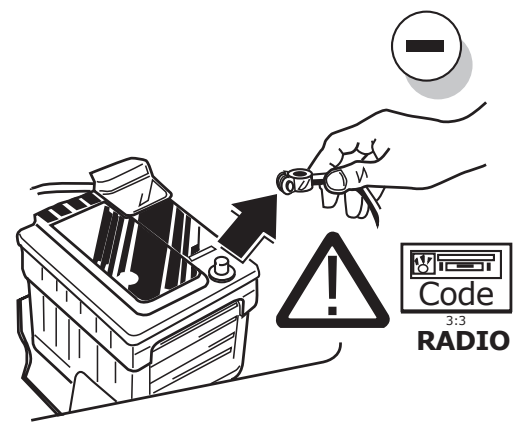

2

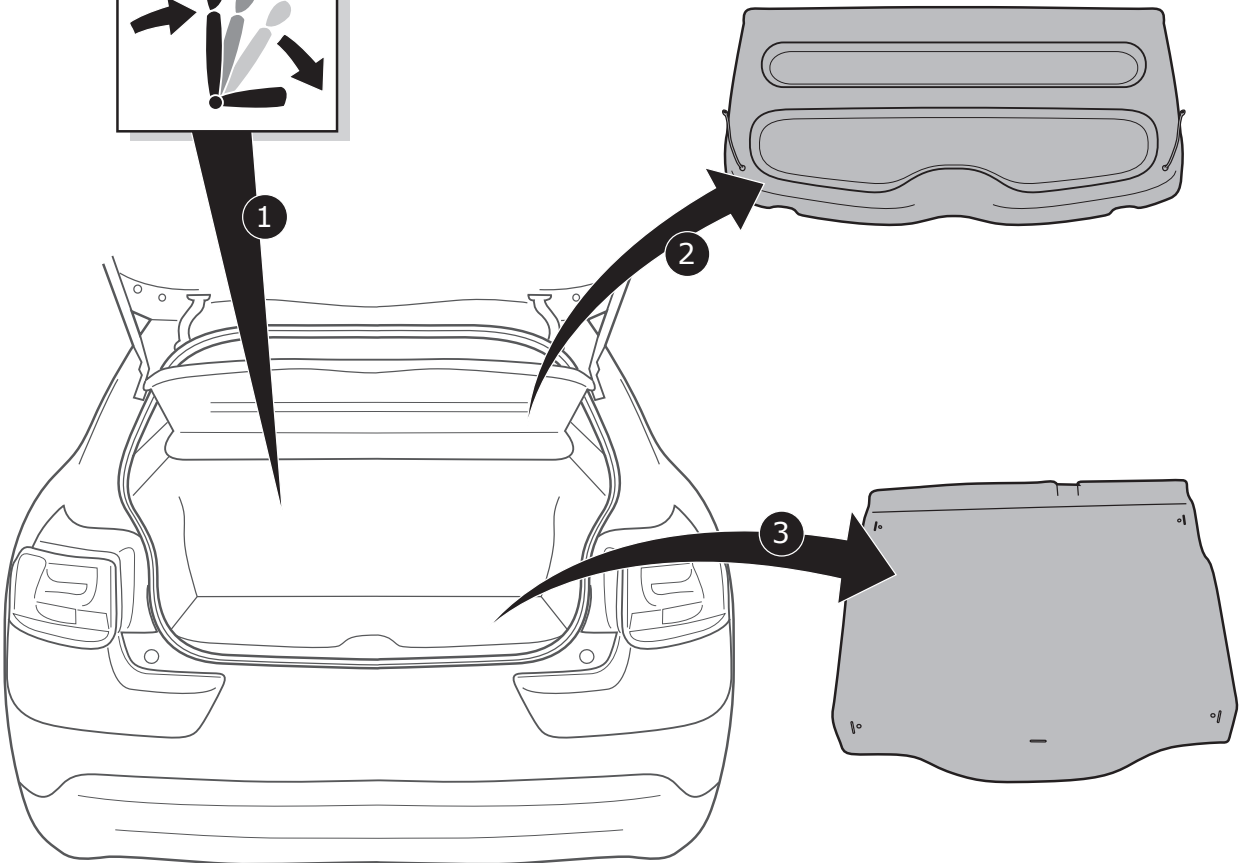
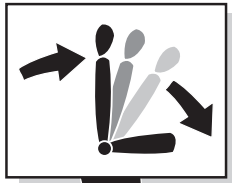

3

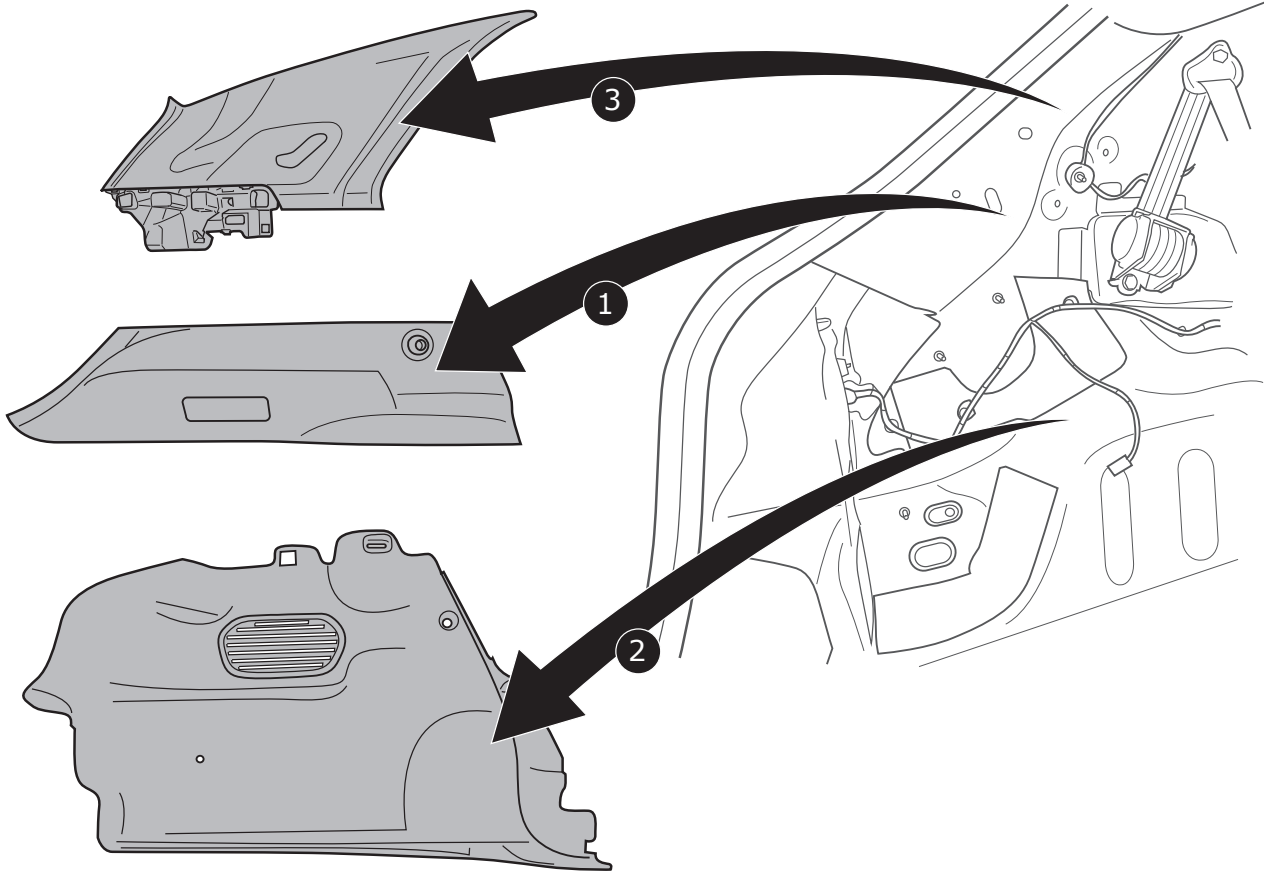

4

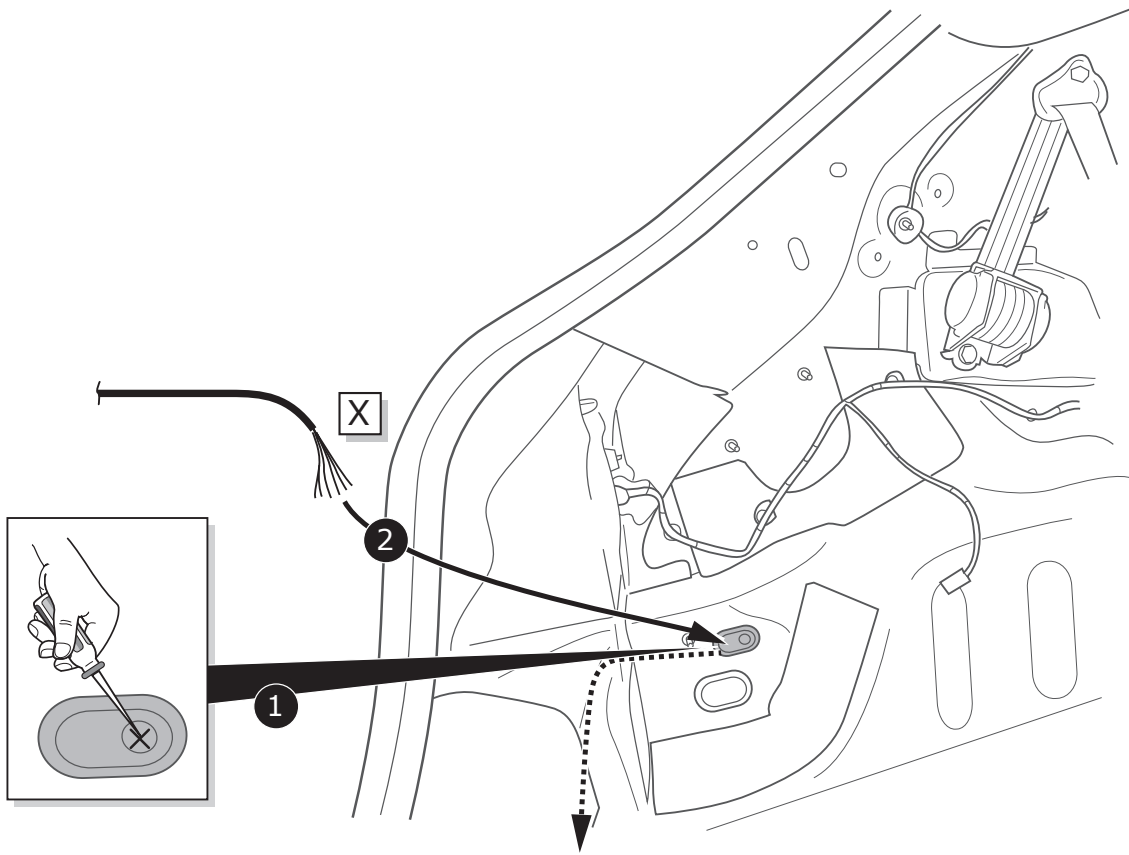

A

Option 1

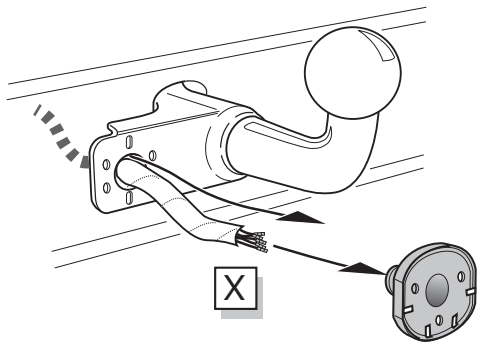

Option 2

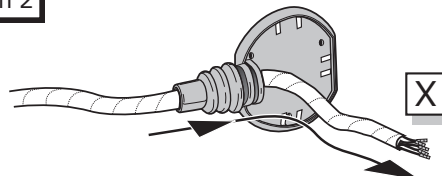

Option 3

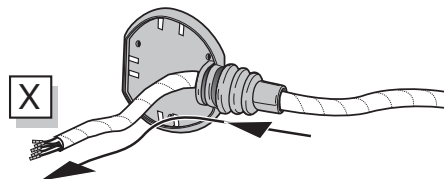

INFO

SOCKET CONNECTION



Page 21

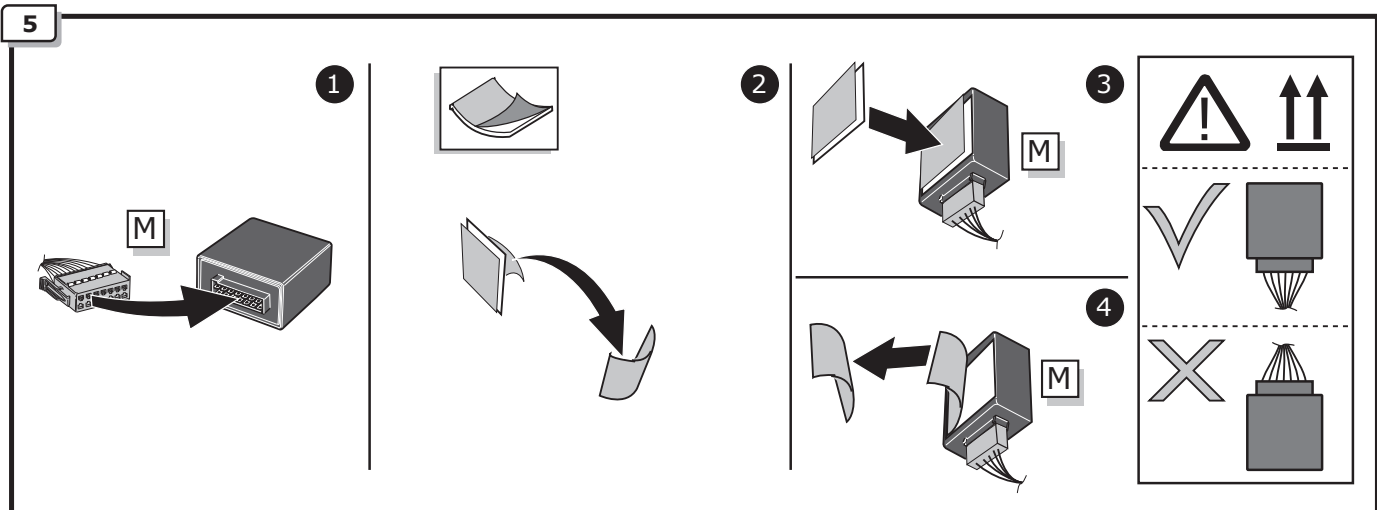
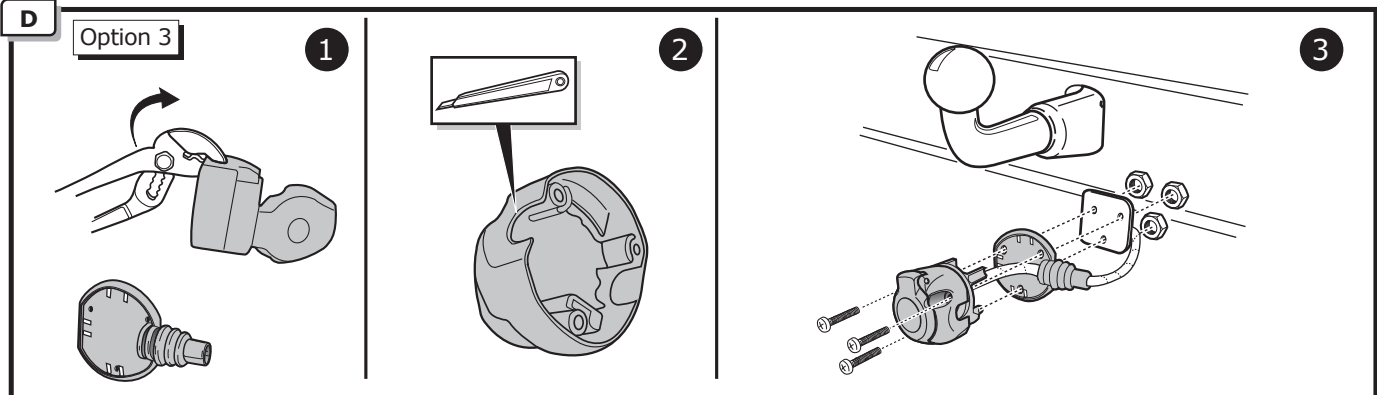
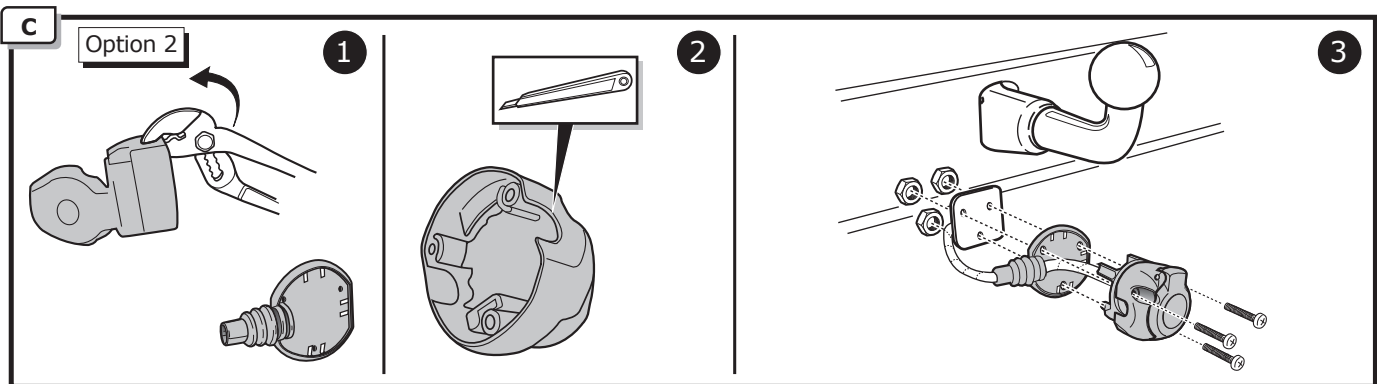
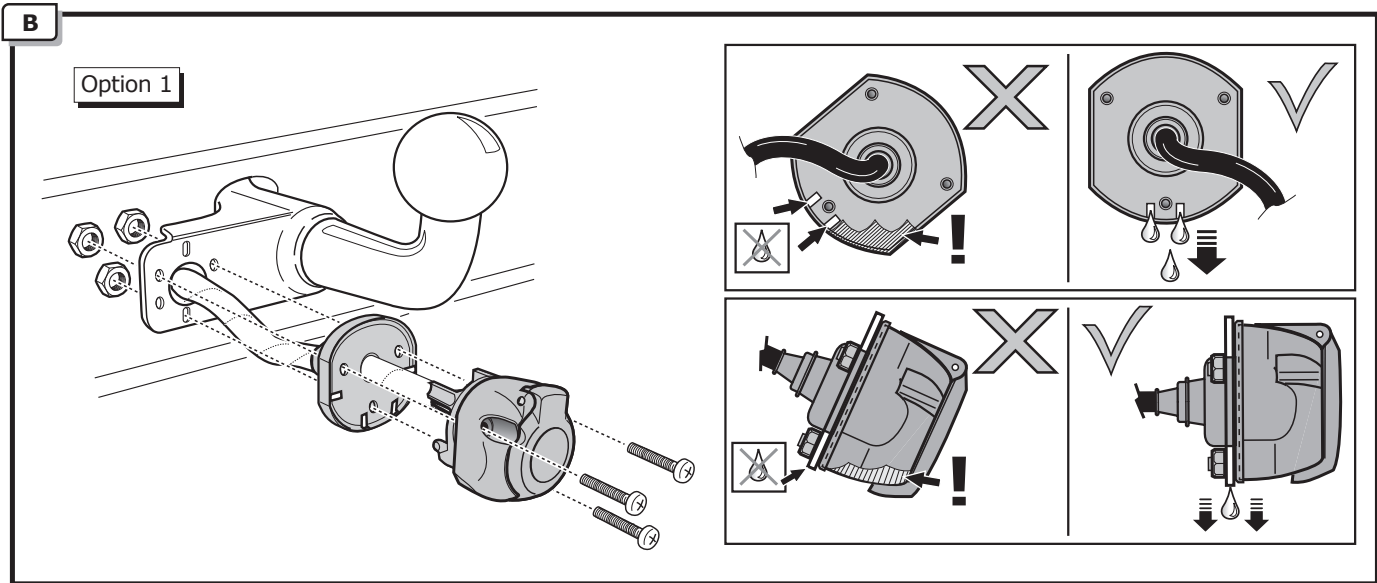

6

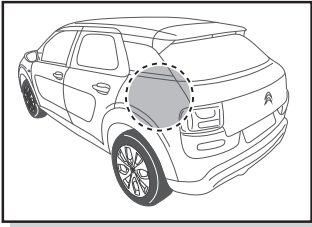

M

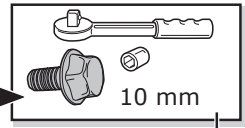
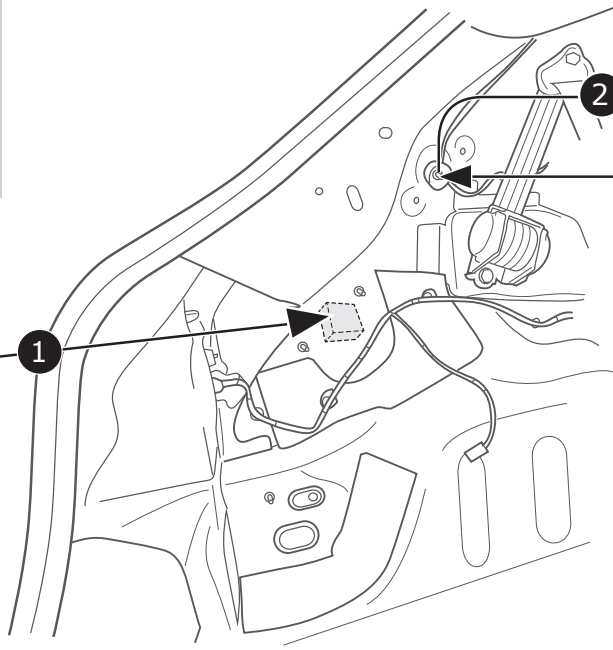
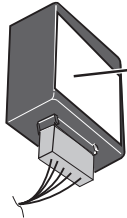

G



7

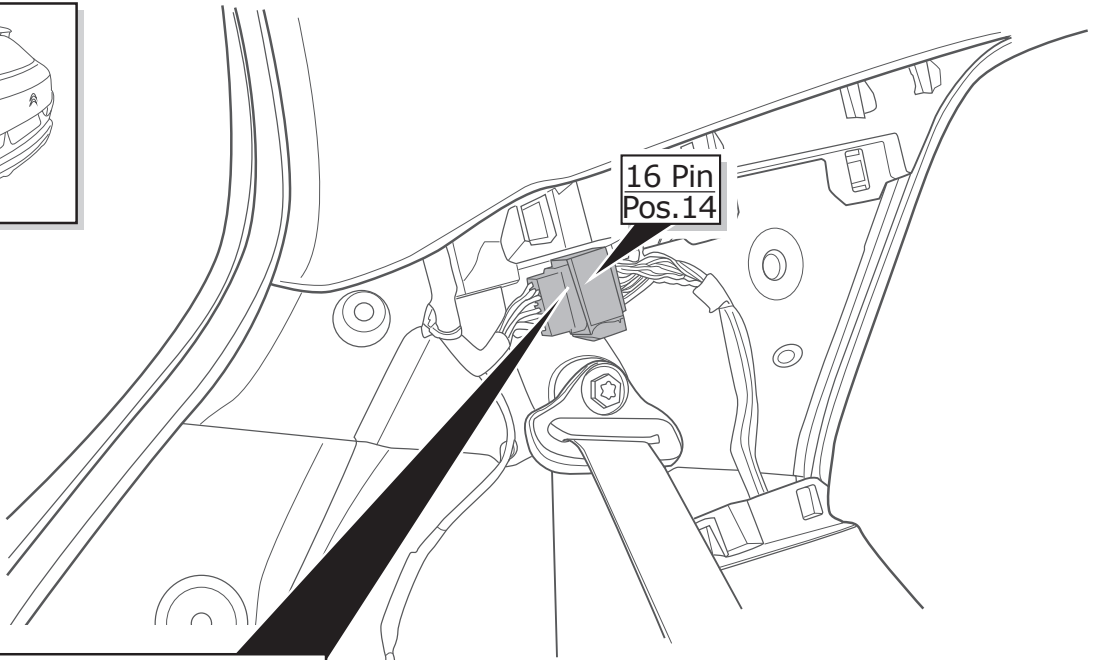
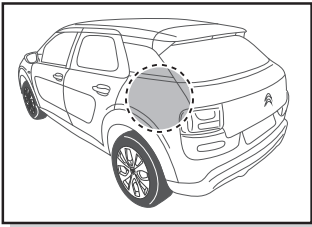

16 Pin  
Pos. 14

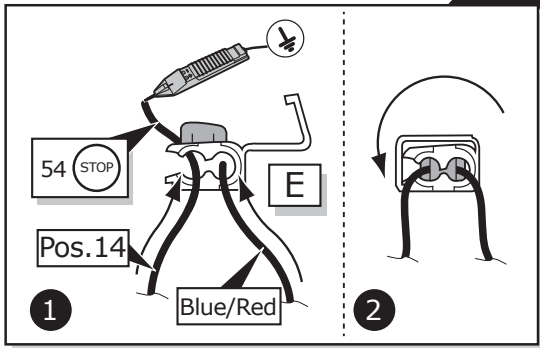

54 STOP

Pos. 14

Blue/Red

1

2

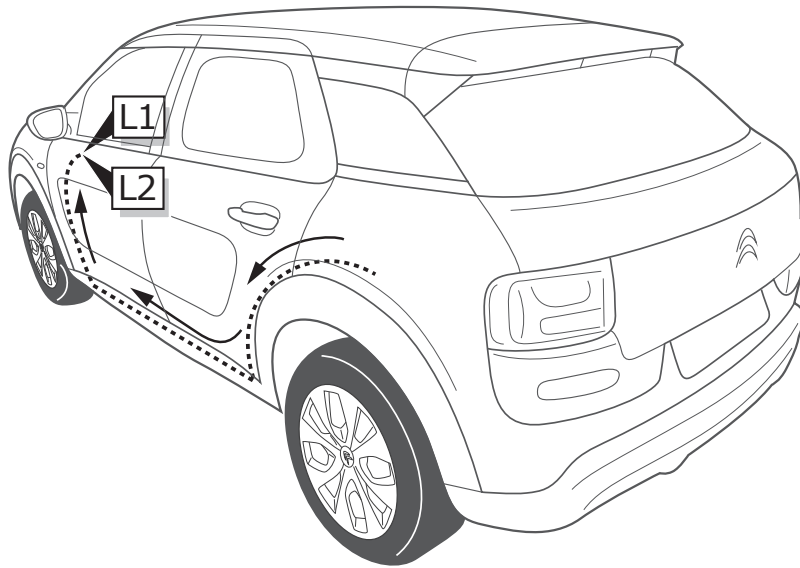

Citroën C4 Cactus 07/2014 >> 02/2018

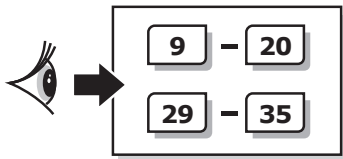

Citroën C4 Cactus 03/2018 >>

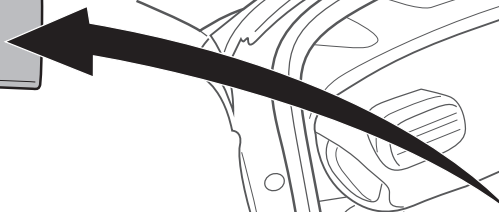
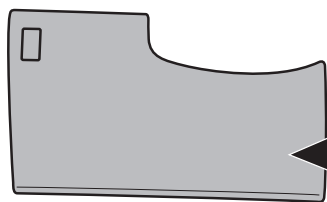
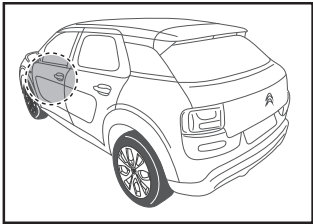
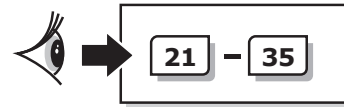



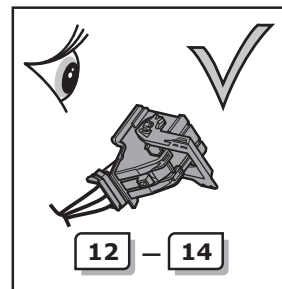
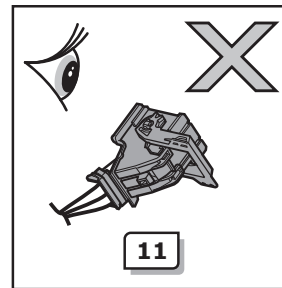
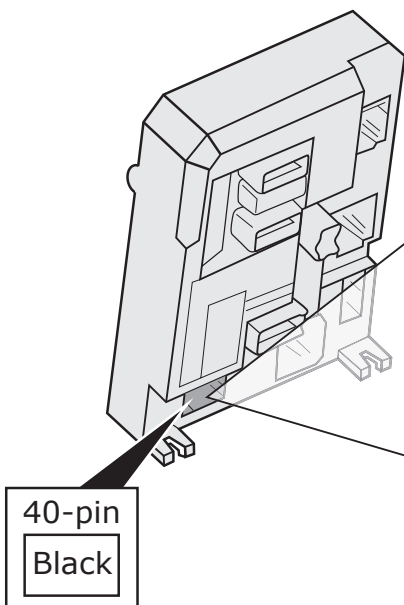
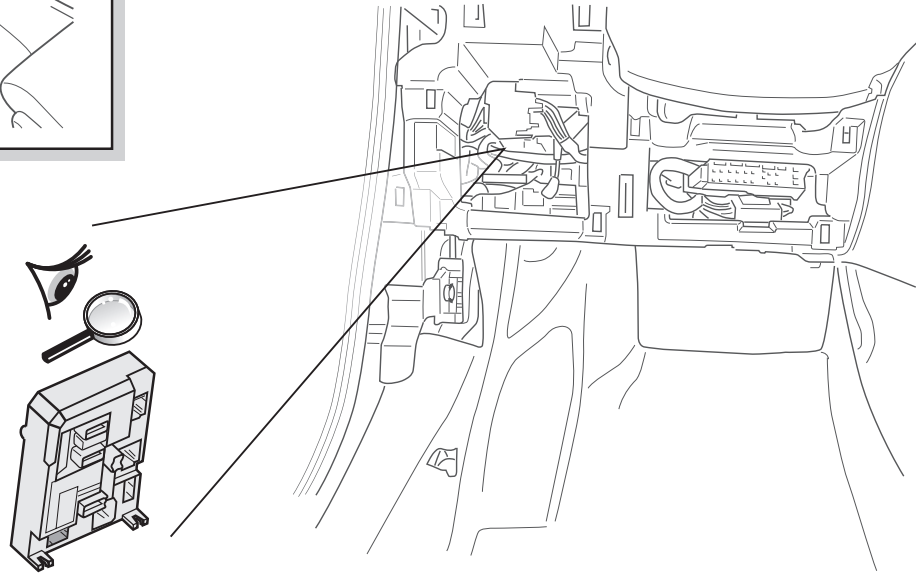
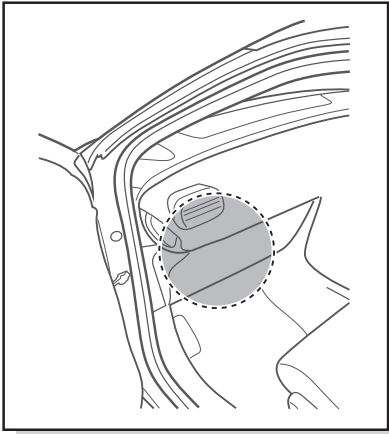

11

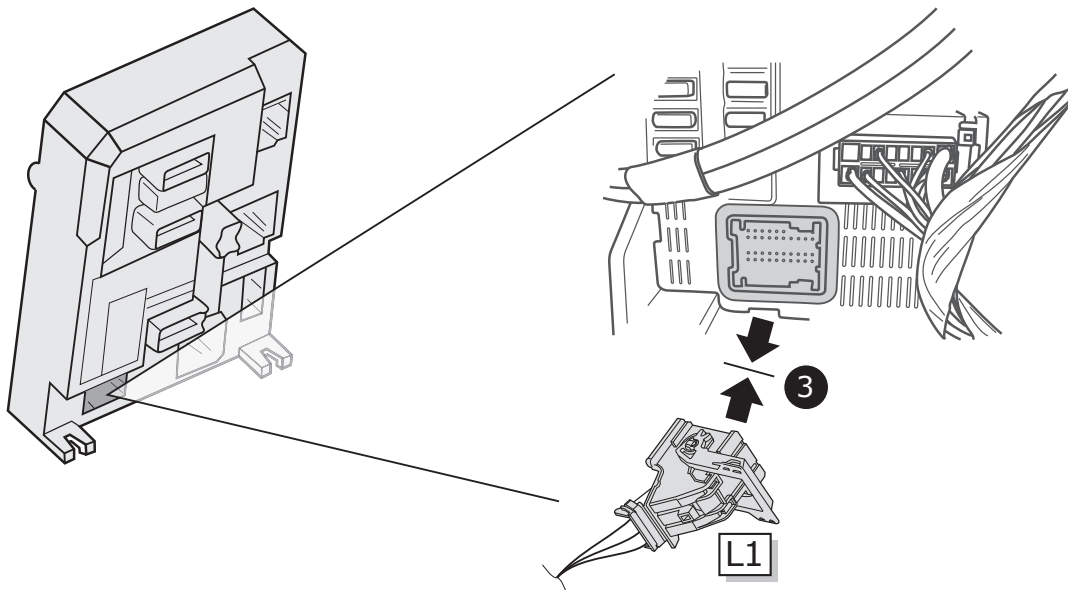
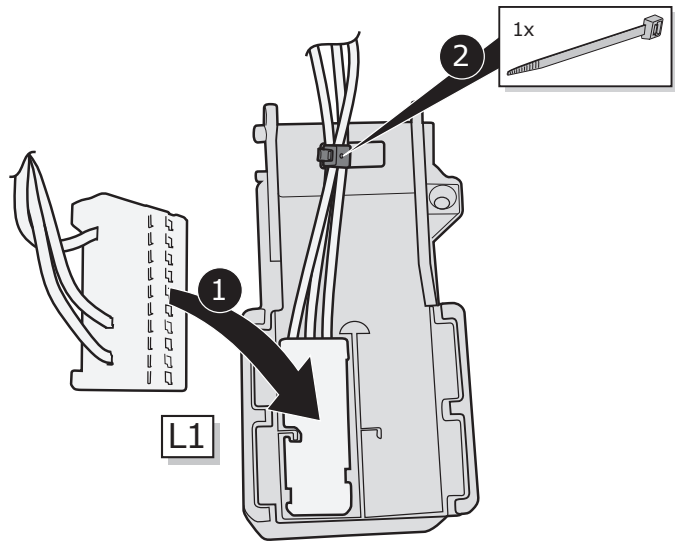
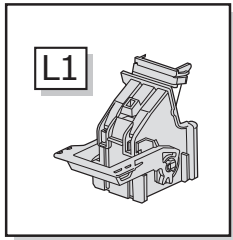
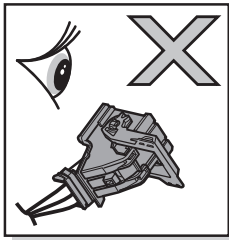

12

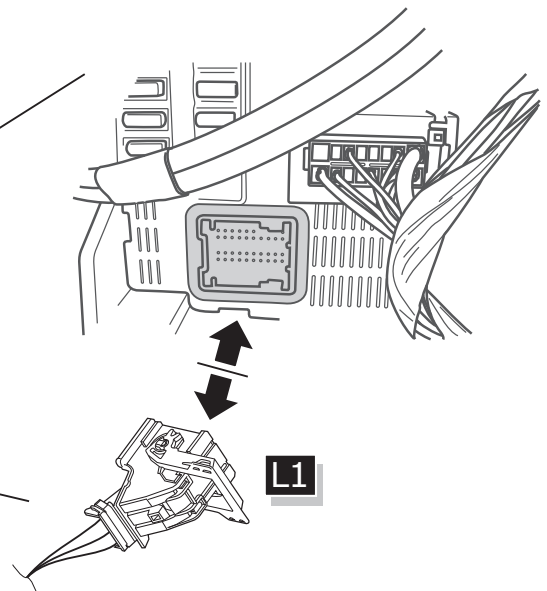
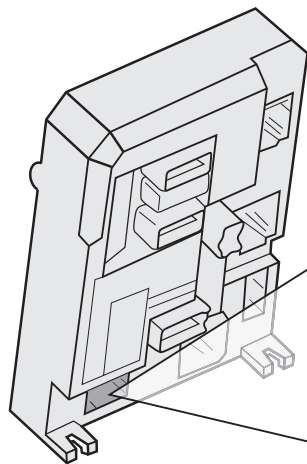
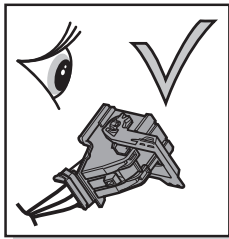

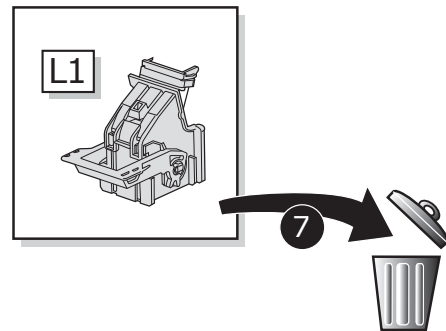
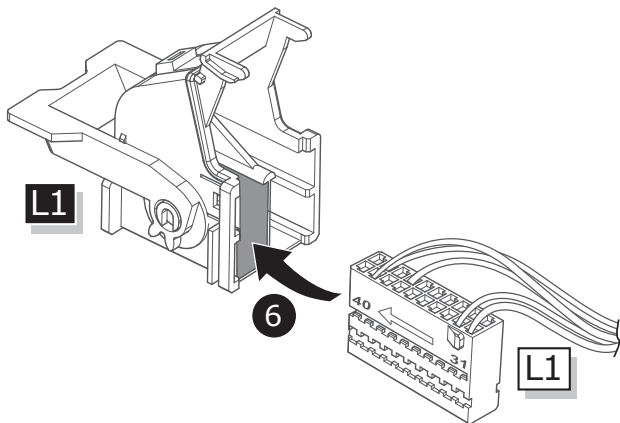
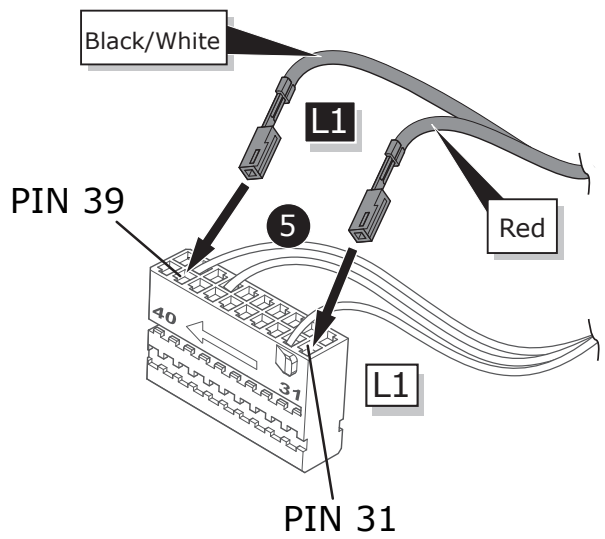
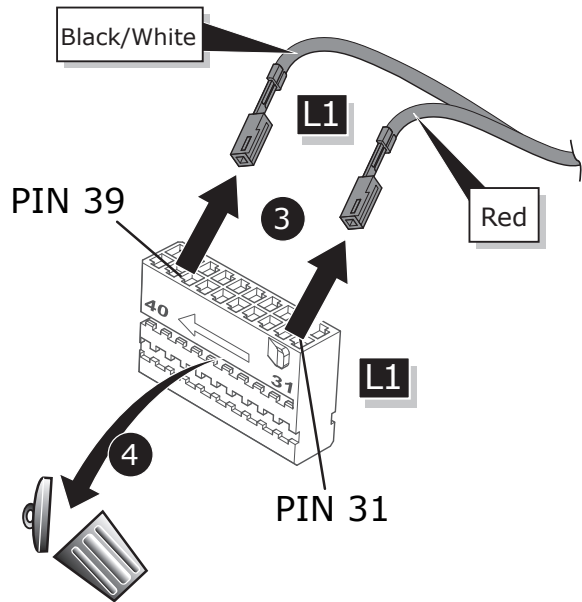
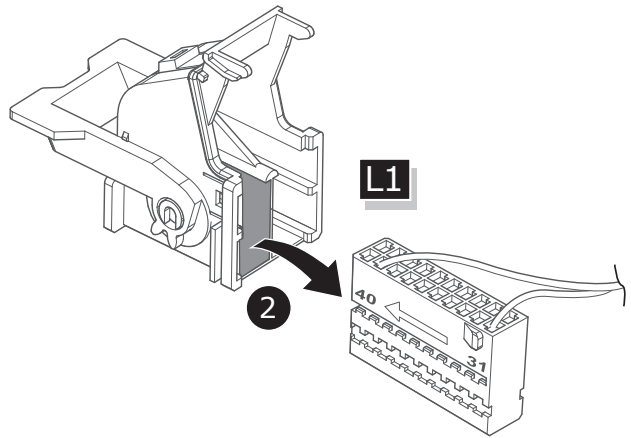
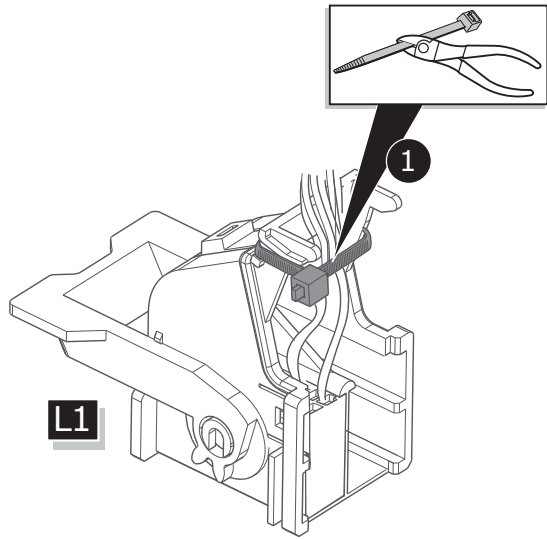

14

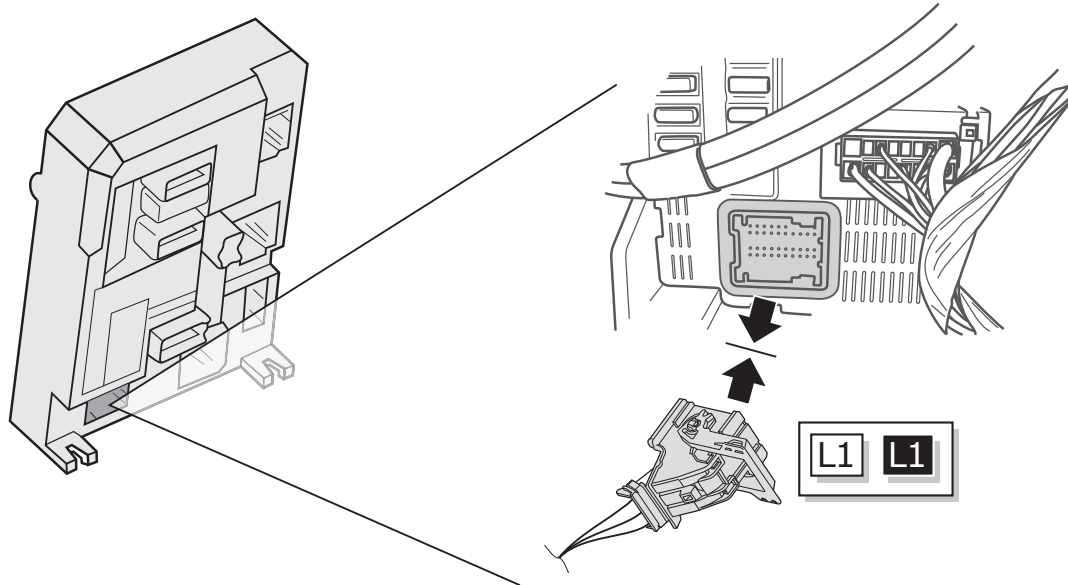

15

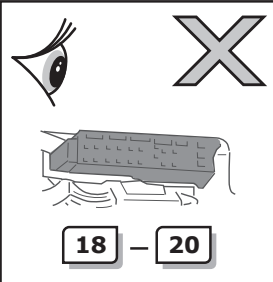
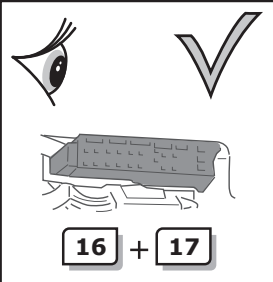
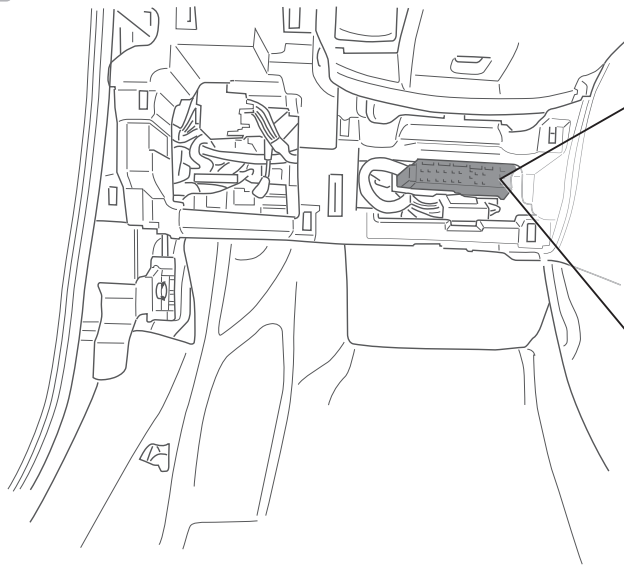

16

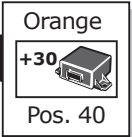
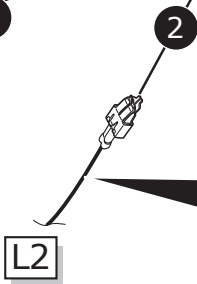
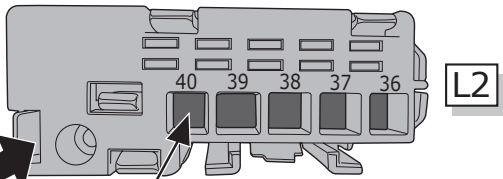
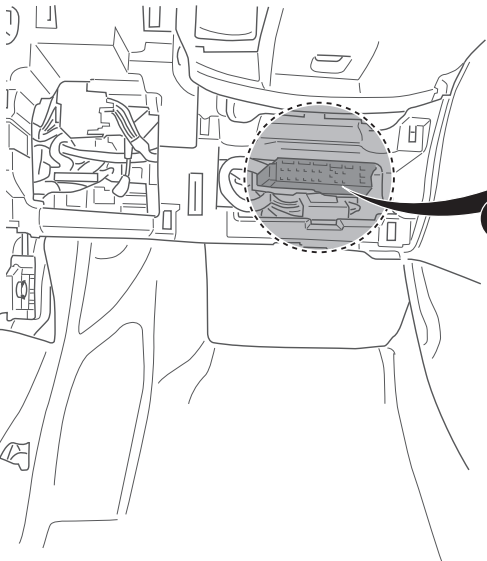
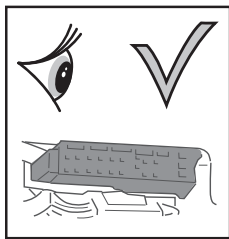

17

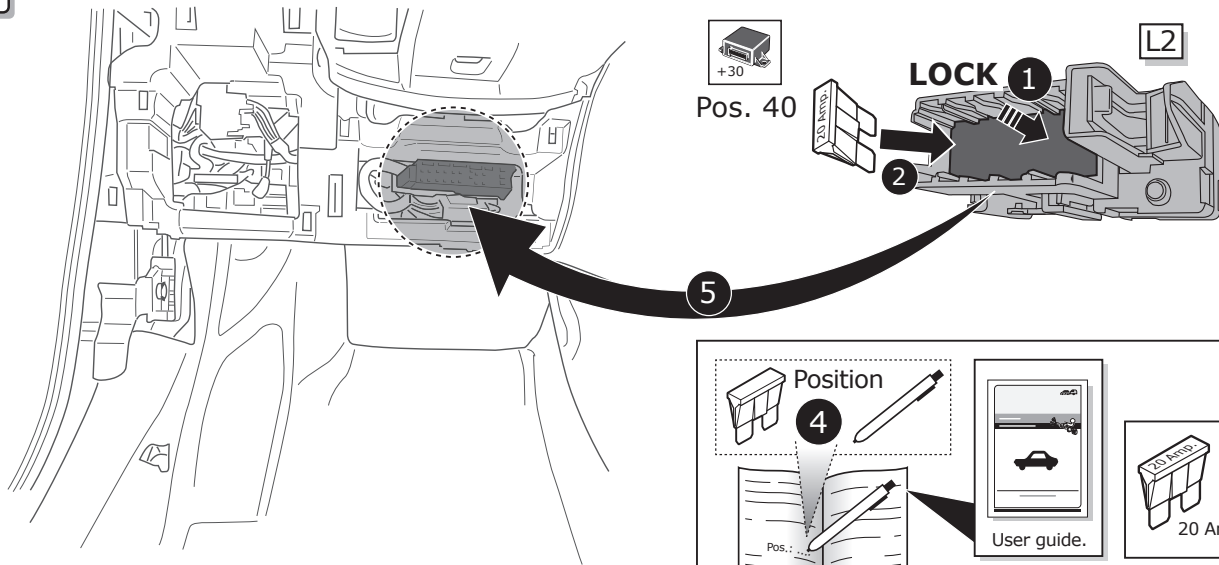

18

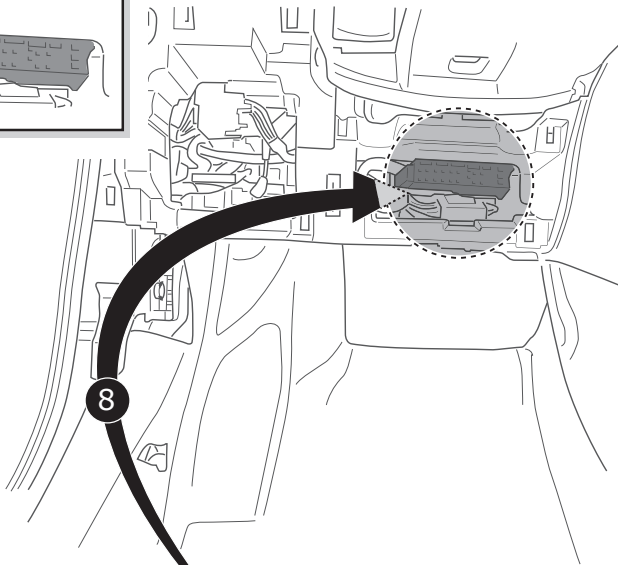
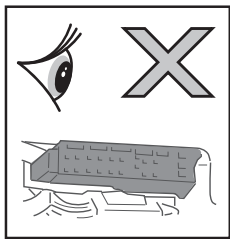

1 UNLOCK L2

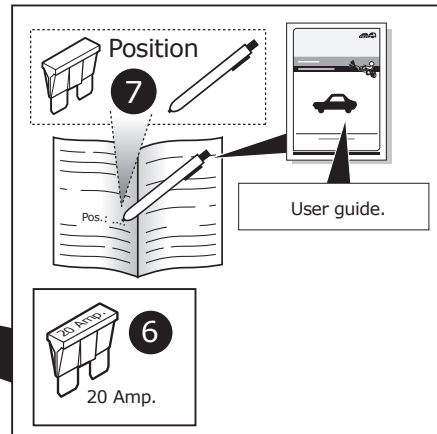
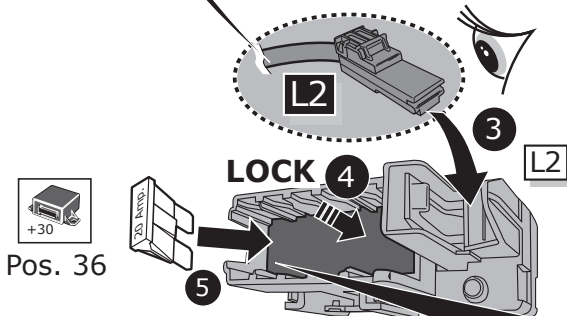
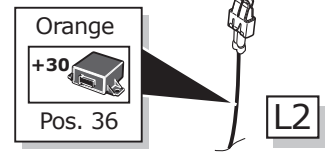
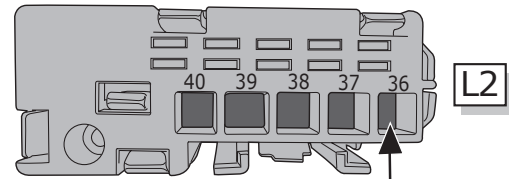
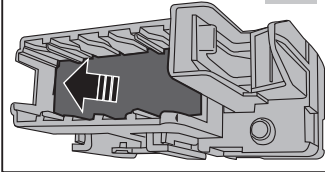

19

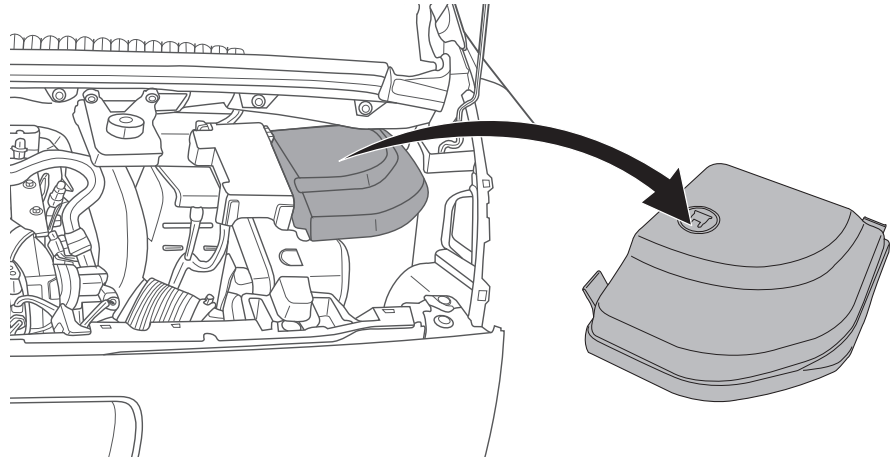
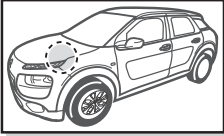

20

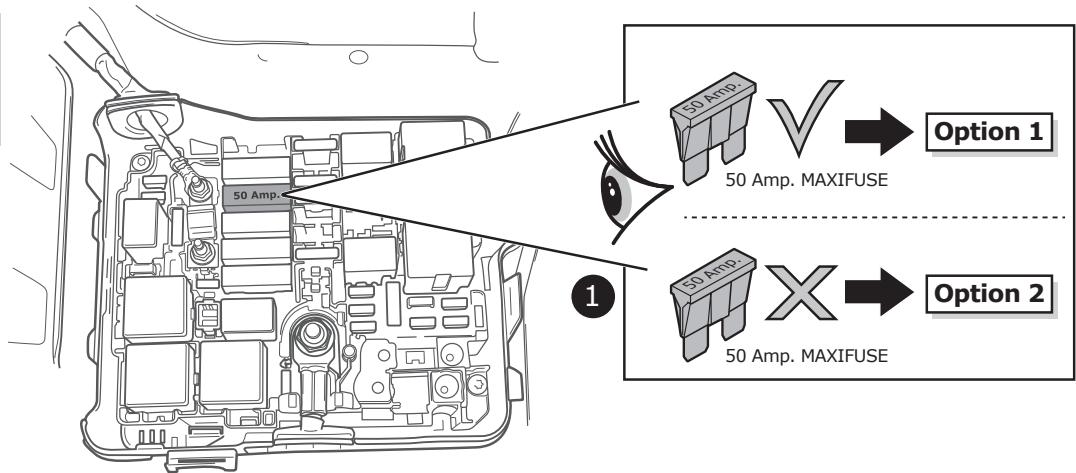
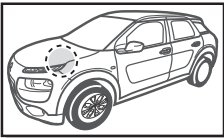

Option 1

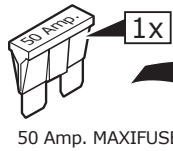
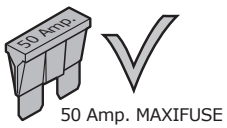

50 Amp. MAXIFUSE



Stored

Option 2

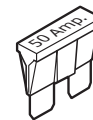
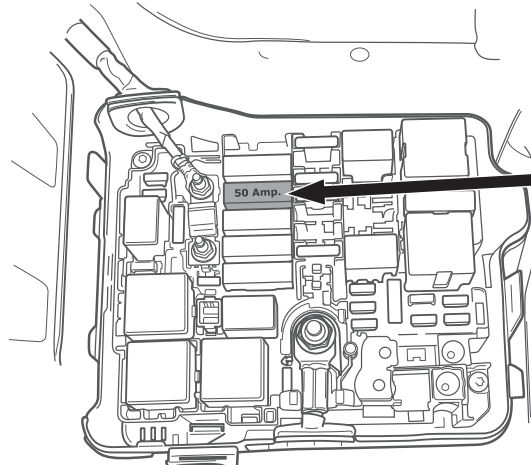
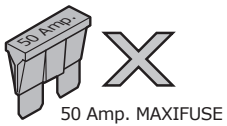

50 Amp. MAXIFUSE

21

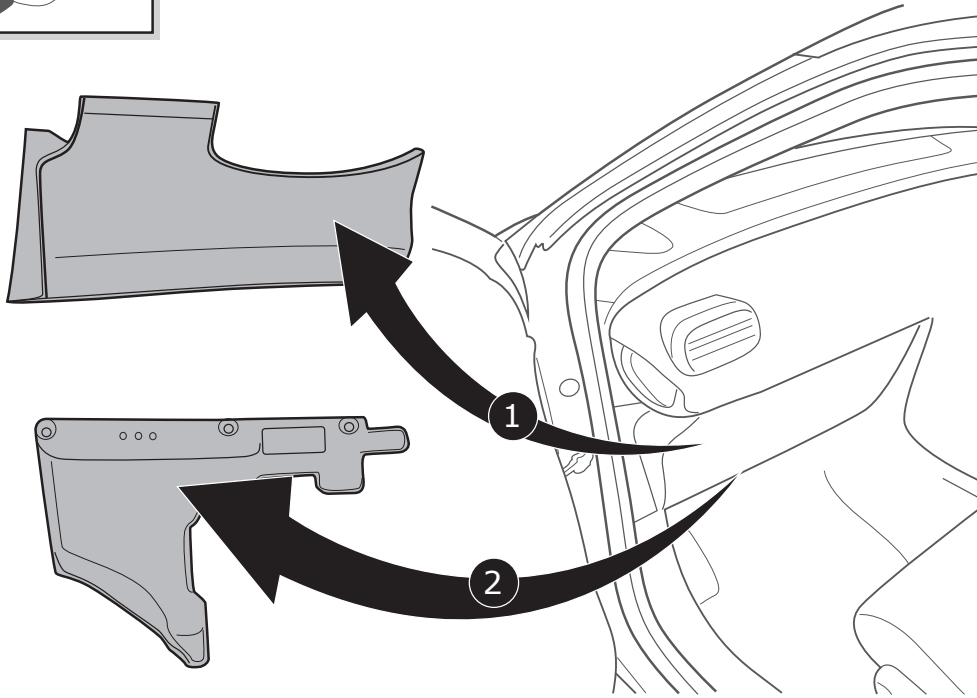
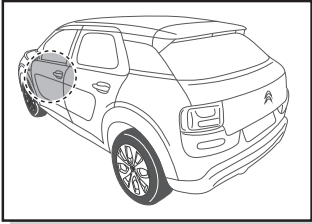

22

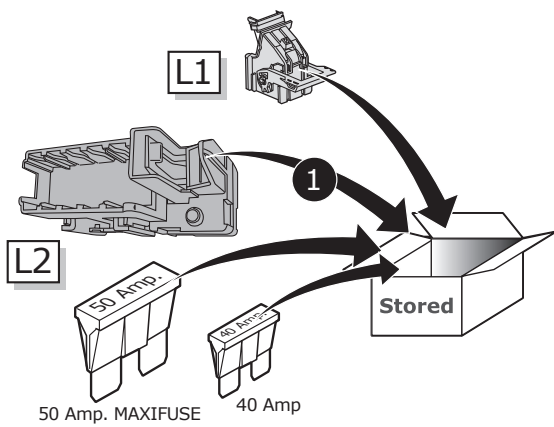

If not used

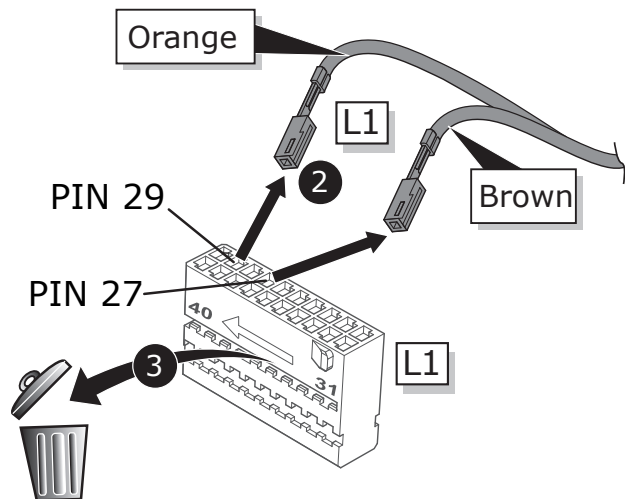

23

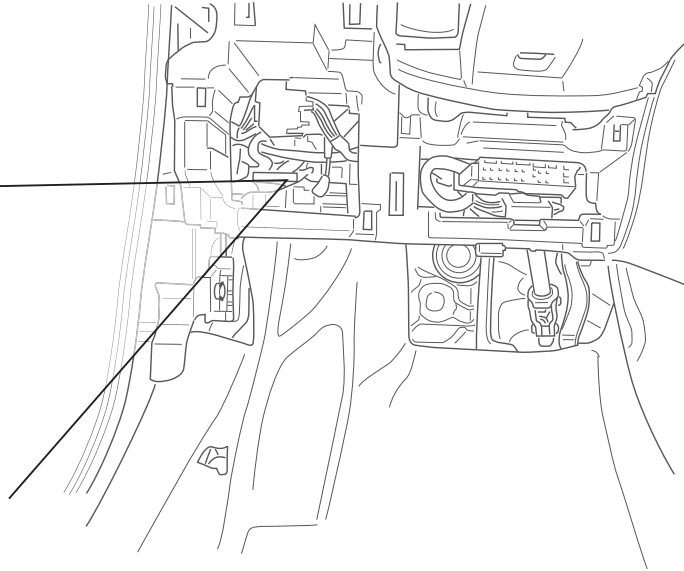
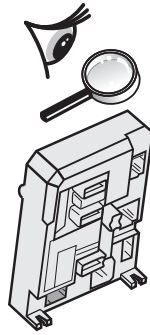
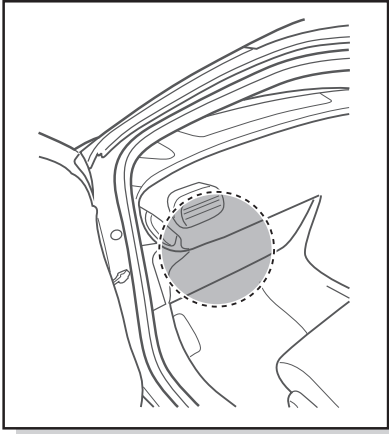

24

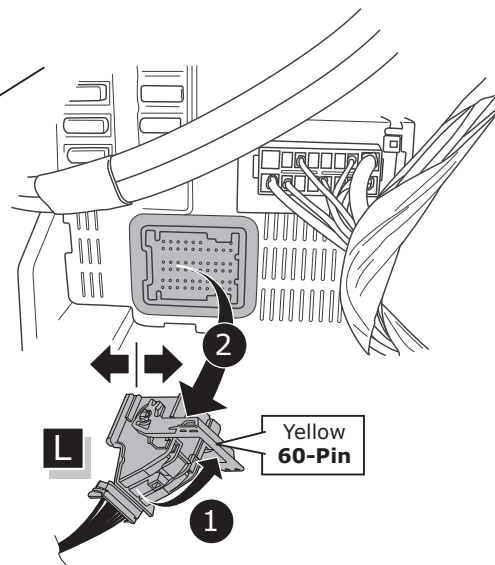
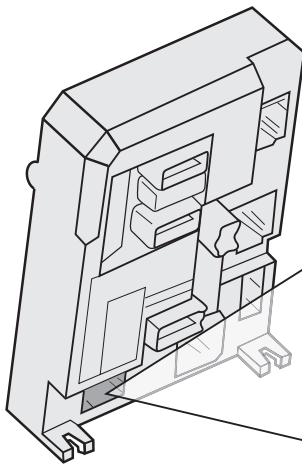



25

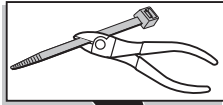

L

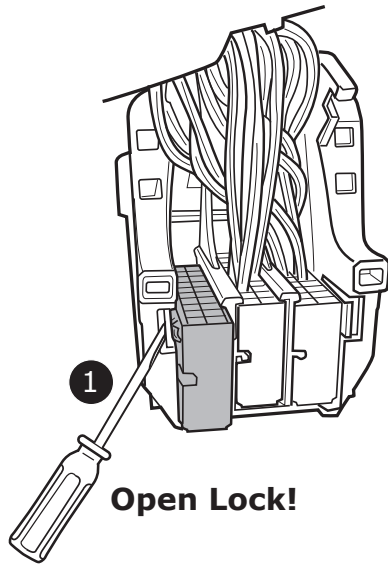
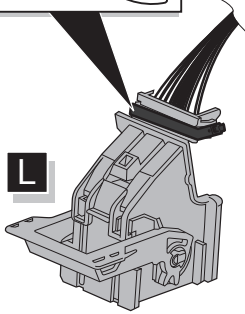

1

Open Lock!

L

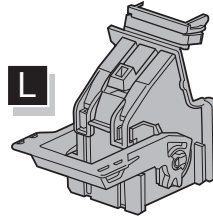

2

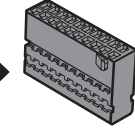

L1

Brown

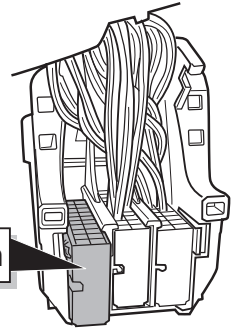

26

⚠	Pin 47 → ←	Brown
	Pin 49 → ←	Orange

Orange

L1

Brown

PIN 49

PIN 47

Brown

L1

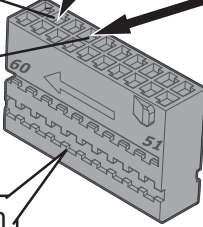

27

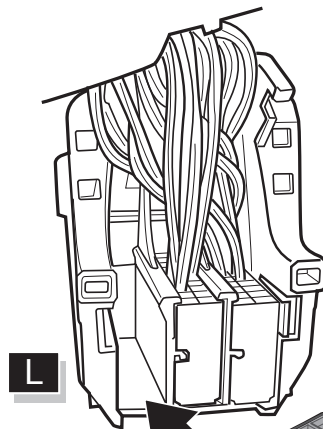

L

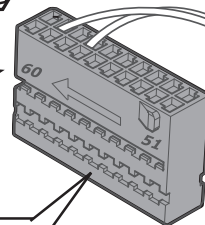

L1

Brown

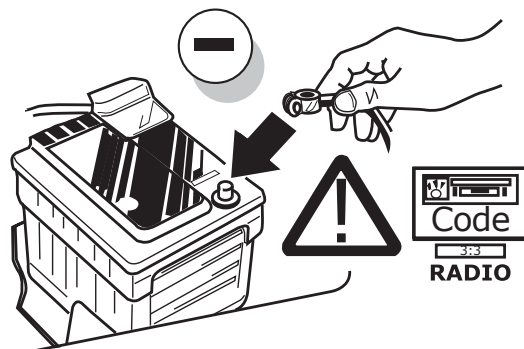
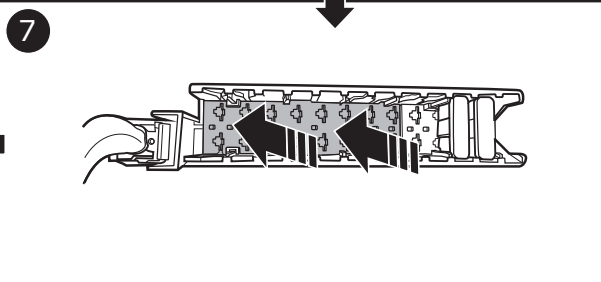
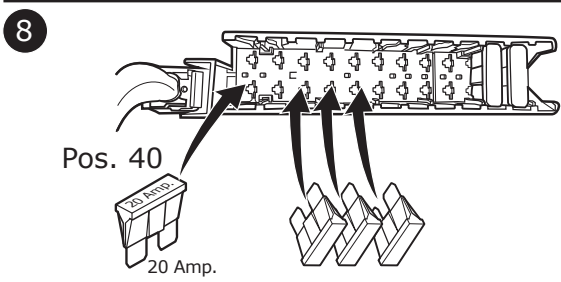
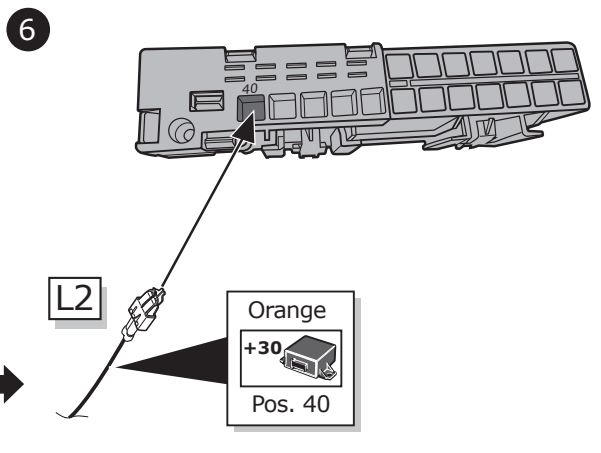
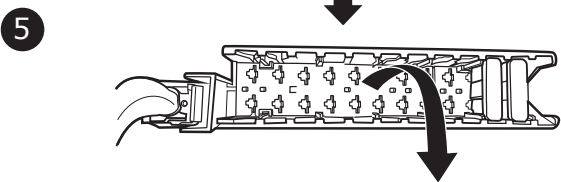
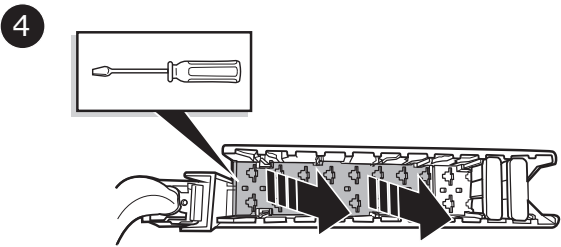
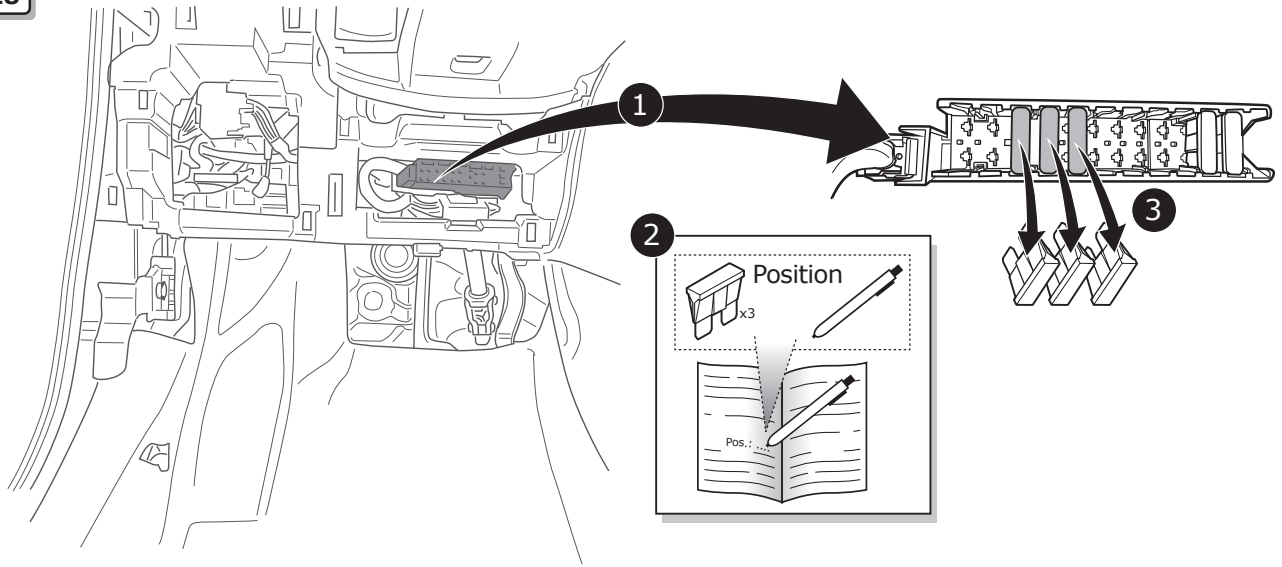

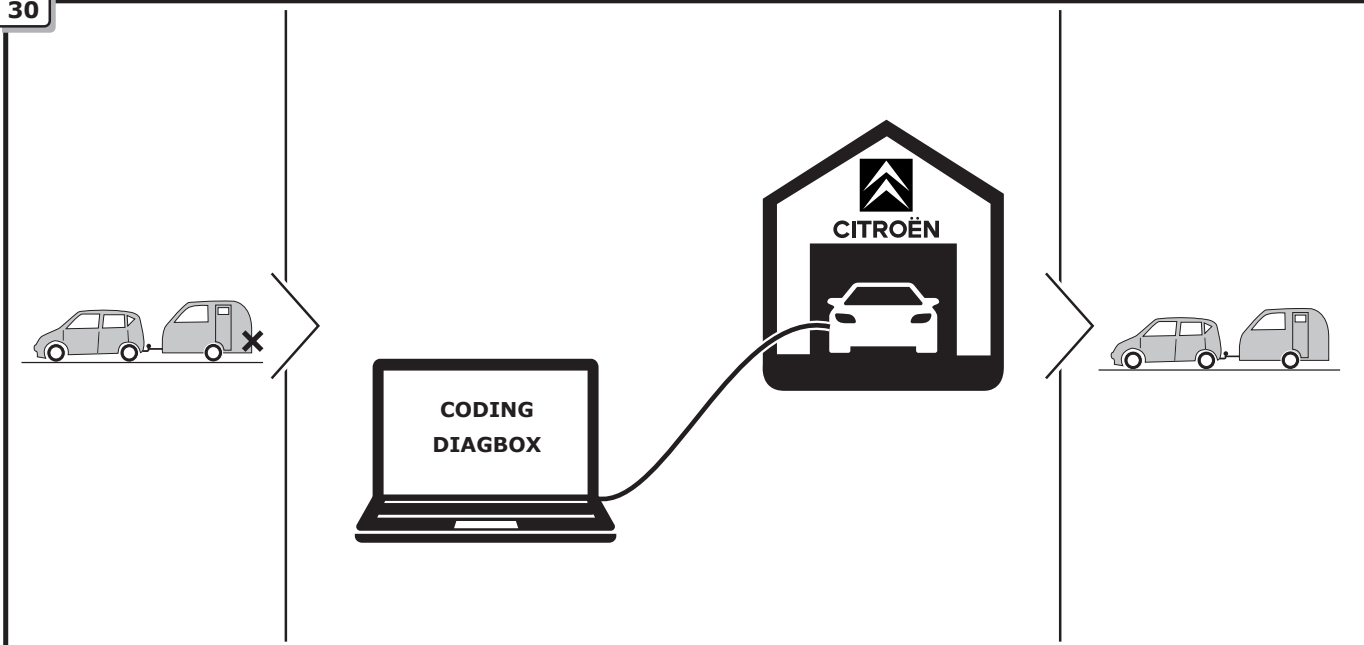

The activation of the trailer functions has to be carried out using the **CITROËN DIAGBOX** as follows:

- choose vehicle
- delivery
- equipment
- trailer control unit (BSR)
- installation of equipment

**Functional test**

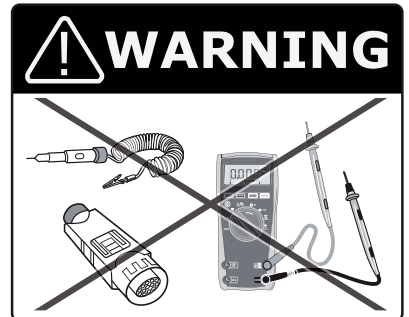
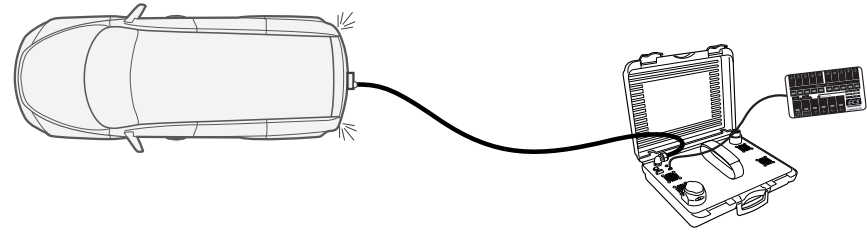
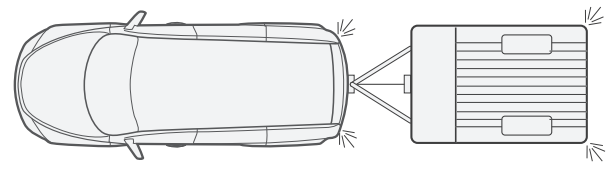
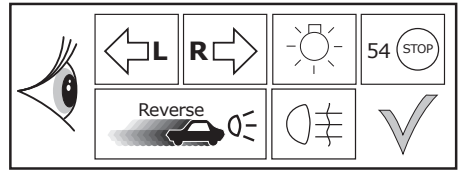

**LIGHTMATE®**

**ECS** part no.  
**LIGHTMATE II**  
**LIGHTMATE III**

32

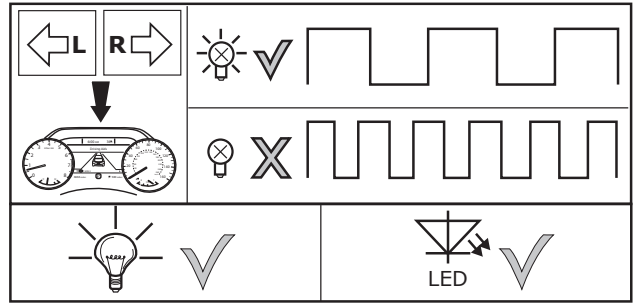
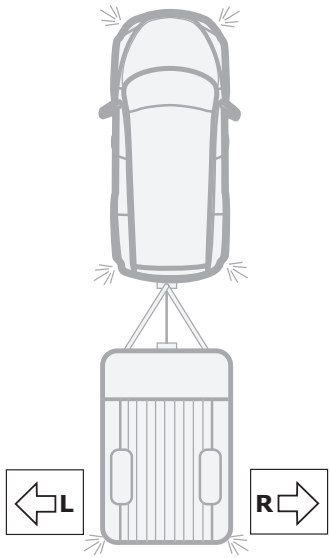

33

Optional

Adapter socket

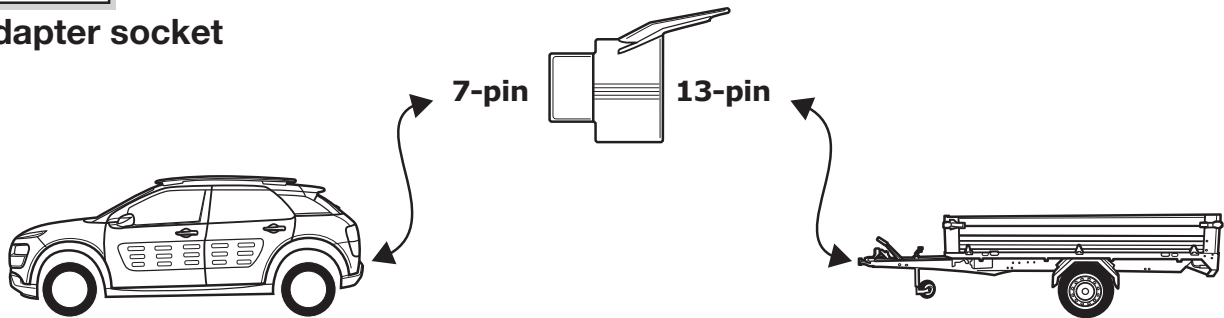

34

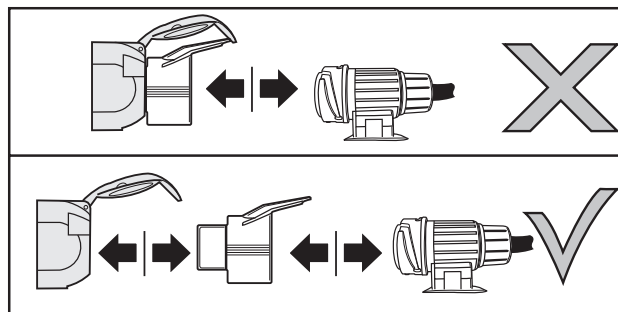
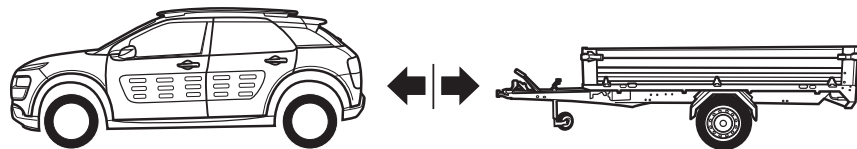

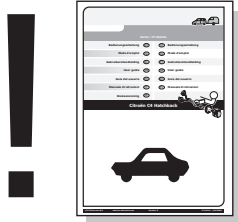
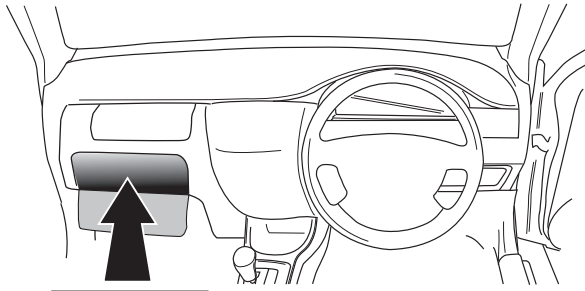

# User guide



**INFO**

## SOCKET CONNECTION

DIN/ISO 1724							
	1/L	2	3/31	4/R	5/58-R	6/54	7/58-L
Pmax	21W	21W		21W	52W	3x21W	52W
Colour	Yellow	Blue	White	Green	Brown	Red	Black

# UN-243-YZ Reverse lamp pre-wire extension

⚠ MAX = 21W

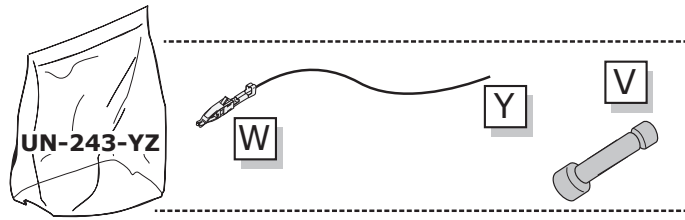

**A**

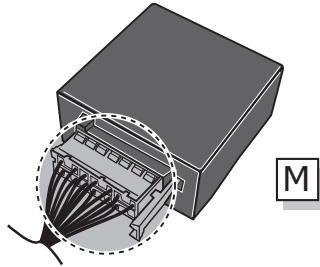

**1**

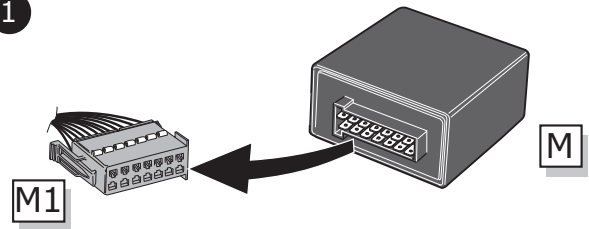

**2**

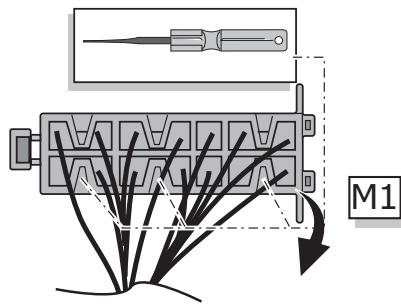

**3**

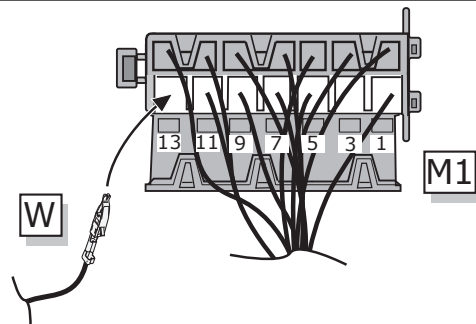

**4**

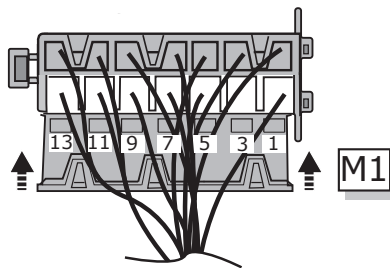

**5**

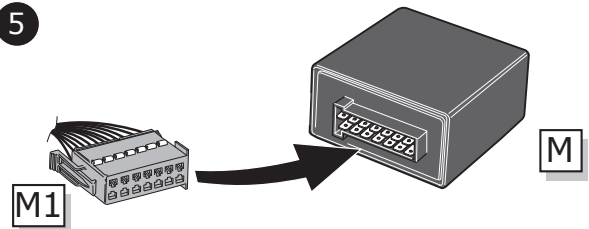

**B**

⚠ MAX = 21W

